

Canale 100 alto **PRATIKO EASY**

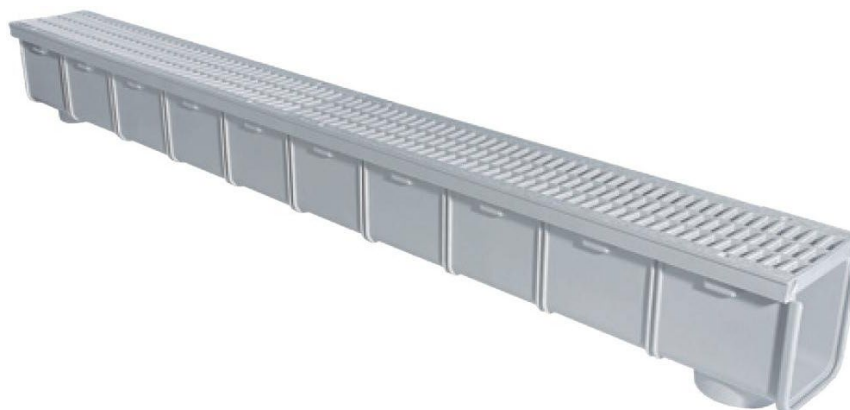

CSASGR100PP

Codice
CSASGR100PP

Il codice **CSASGR100PP** è composto dai seguenti prodotti:

- n. 1 = CSA100PP
- n. 2 = SGR100PP

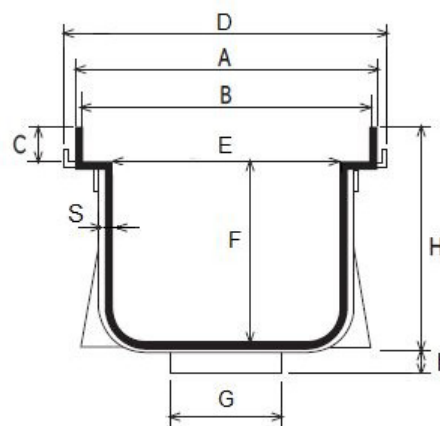
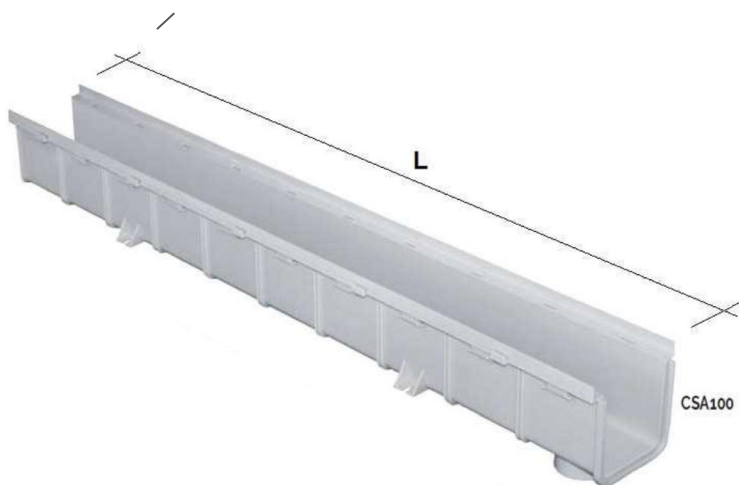

Codice	A mm	B mm	C mm	D mm	E mm	F mm	∅ G mm	H mm	h mm	L mm	S mm
CSA100PP	104	99	13	115	75	60	40M - 50M - 63M	55	18	1000	2,4

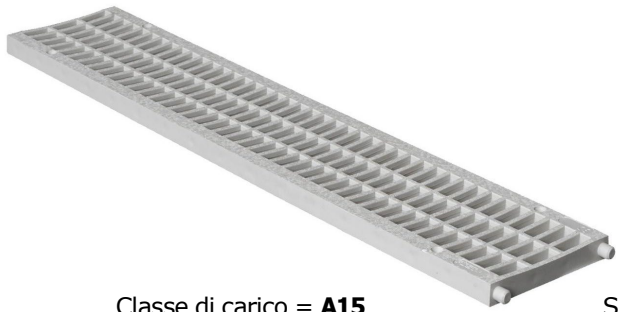

Classe di carico = **A15**

SGR100PP

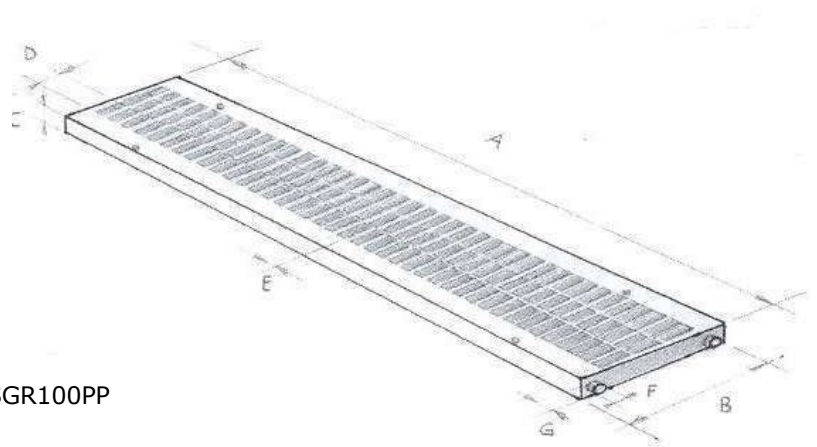

Codice	A mm	B mm	C mm	D mm	E mm	∅ F mm	G mm	Peso g
SGR100PP	500	99	13	23	8	7,5	8	400

Materiale: CSA100PP "Polipropilene" - SGR100Polipropilene

Caratteristiche: I canali permettono di risolvere tutte le problematiche di drenaggio di acque meteoriche all'interno di parcheggi, cortili, piazzali e garage.

