

Helical extractors

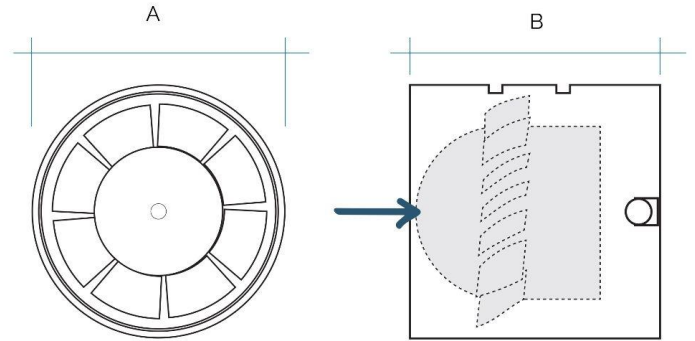

To be installed in rigid or flexible ducts \varnothing 100 mm and \varnothing 125 mm.
You can join AA100T tube with \varnothing 100 mm tube using CG100B joint.

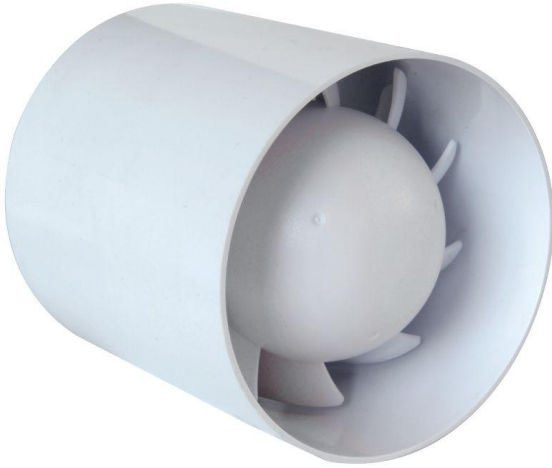

Item	Colour	AxB mm	Air flow m ³ /h	P watt	Noise dB	Suitable for holes \varnothing mm
AA100T	white	97x100	104	15	41	100
AA125T	white	118x100	158	16	43	120/125

Description: Wall-mounted helical extractor for ducts

Features: The helical aspirator for ducts is a simple and versatile solution to solve the problem of air exchange for a certain type of domestic environment, such as service bathrooms or laundry rooms. Helical extractors are suitable for direct wall outlet or for installations where it is not necessary to flow the air on very long distances through the ducts.

