

Outdoor unit anti-vibration floor plastic mounting blocks

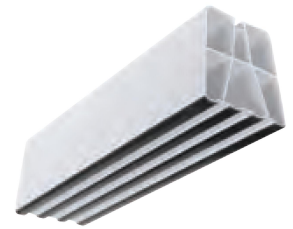
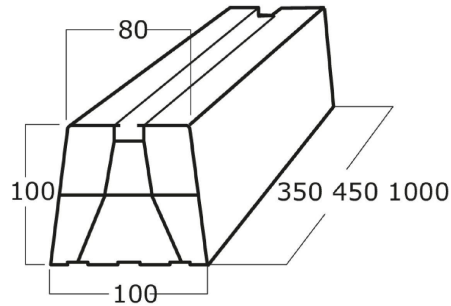

View of pre-assembled strips from below

Item	Colour	Dimensions L x B x H mm	Load capacity kg for couple
EPLUS350P	white	350x100x100	380
EPLUS450P	white	450x100x100	380
EPLUS1000P	white	1000x100x100	380

Description:

Bi-extruded PVC floor base for outdoor units

Material:

Bi-extruded shockproof and UV resistant PVC

Features:

Bi-extruded PVC mounting blocks with fixing kit included. Faster installation thanks to pre-assembled anti-vibration strips.



Item	Colour	Dimensions L x B x H mm
EPTPLUS	white	100x100

Description:

Mounting block end cap

Material:

Bi-extruded shockproof and UV resistant PVC

