

Outdoor condenser unit wall brackets

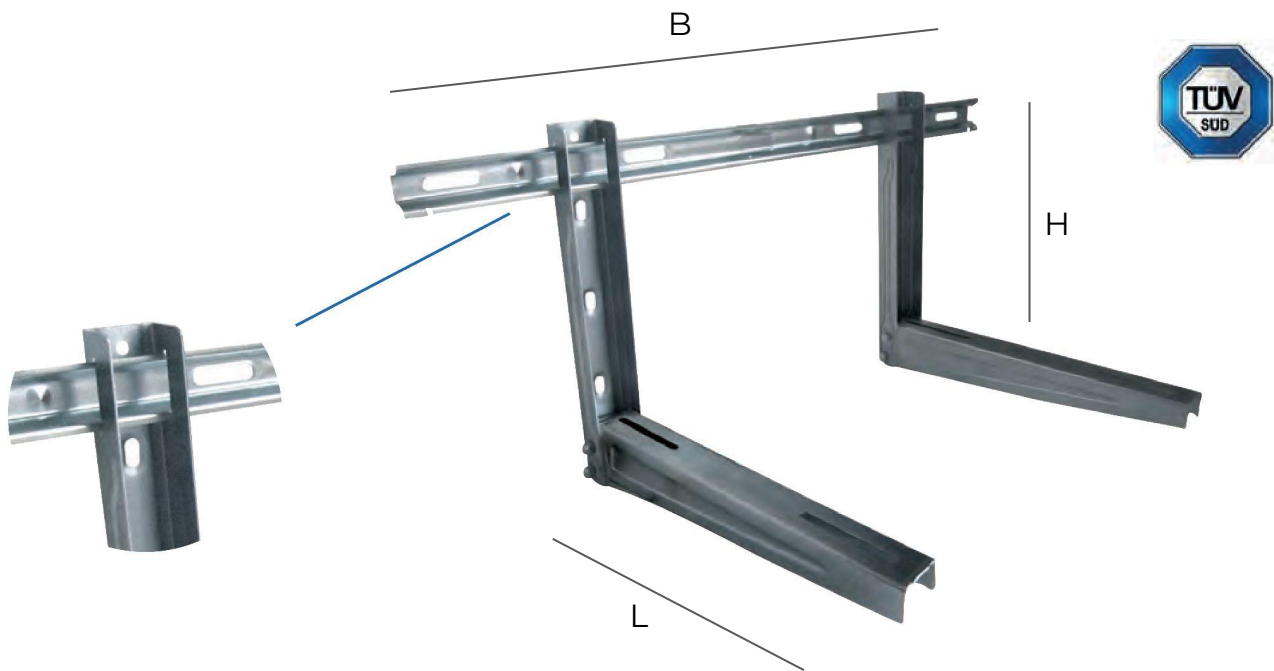

Item	Colour	Dimensions L x H x B mm	Load capacity kg
EPSIN520	white	520x400x800	160

Description: Universal adjustable stainless steel wall bracket for outdoor unit

Features: The universal adjustable bracket in AISI304 stainless steel for outdoor units is complete with vibration dampers, steel screws, plugs, spacer foot, for simple, fast and correct installation.
The load capacity for the bracket is certified

