

Wall built-in acoustic reducer

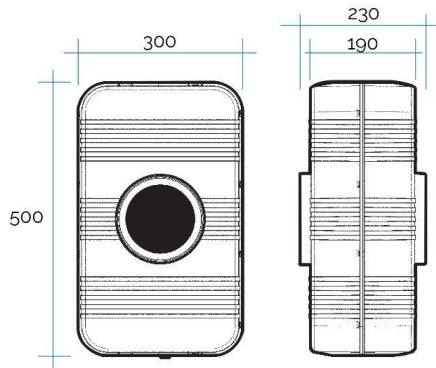

Certified acoustic insulation

Certified air passage

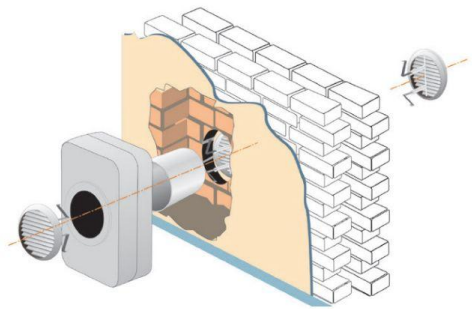
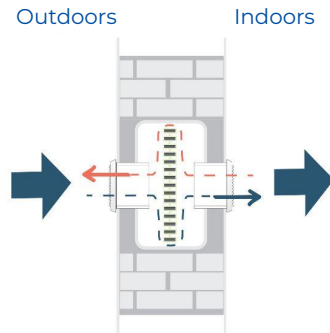
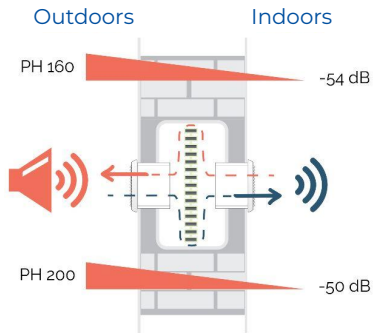

Item	ø Hole mm	Noise reduction dB	Pass Air cm ²
PH160	160	up to -54	100
PH200	200	up to -50	160

Description: Acoustic reducer for ventilation holes PHONOBX

Material: Box: ABS plastic
Sound-absorbing material inside the box: expanded polyurethane

Colour: Grey

Features: PHONOBX is a patented soundproofing device suitable for ventilation holes in perimeter walls. The product allows a certified noise reduction of 54 dB (tests carried out in compliance with current regulations) with an air passage of 100 cm² in compliance with the UNI CIG GAS 7129 standard. PHONOBX is complete with: 2 white ventilation grilles, 1 PVC pipe, 2 jet stop caps.

