

## Condensing boiler pump kit

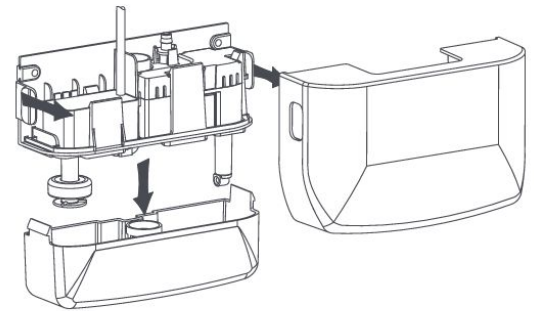
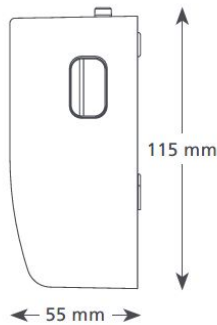
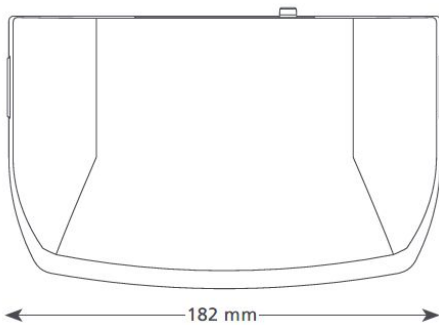
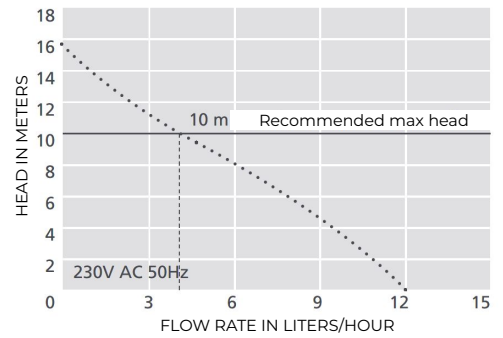

Item	Colour	Noise level dB(A)	Protection rating	Max flow rate l/h
PSSCKI	white	21	IP21	12

**Description:** Condensing boiler pump kit

**Features:** Condensing boiler pumps are ideal for condensate drain and heat recovery. They are installed under domestic gas boilers and ovens.

- Required power supply 230V AC - 50/60Hz
- Max head 10 m
- Tank capacity 0,24 l
- Pipe diameter 20 mm (inlet), 6 mm (outlet)
- Applicable up to 45 kW with condensate pH >2.7

Kit contents: • Pump (including 1.5m power cable) • 6m drain pipe (6mm internal diameter) • Inlet adapter for 22 and 28mm pipe • Pipe adapter • Fixing kit • Manual installation.

